

MERCAN Serie (DN20) Multi-Jet Dry Dial Water Meter for Cold Water

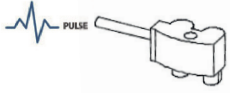

Main Characteristics:

- Approved in accordance with MID
- Multi-Jet dry dial register type with vane-wheel
- Brass housing material
- Durable internal removable strainer and non return valve
- Removable measuring mechanism
- Metrological range -horizontal- R100 (Class B)
- 360° rotating lid
- Horizontal installation
- Magnetic transmission
- Register cap made of brass
- High resistance to water impurities
- Available for optical direct reading
- Electrostatic e/p powder painted
- External adjustable screw
- Water temperature up to 50°C
- (QR) Code to send data for viewing - optional
- Equipable with Pulse output, M-Bus (Wire, Wireless), RF
- Spare parts and service available for 10 years
- 2 years of guarantee

Available options:

The meter could be pre-equipped for future integration of remote reading devices such as M-Bus wire, M-Bus wireless OMS, Non-magnetic pulse output, AMR and upon request LoRa, LoRaWAN, Sigfox

Approvals:

EC type-examination certificate in conformity with

- 2014/32/EU (MID) MI-001 Water Meter
- OIML R49-1 :2006
- EN 14154:2005+A2
- ISO 4064:2015
- EC Type Examination Certificate (RO - 2275- 15286)
- The Quality Assurance of Production Process (Module D)
- Sanitary Compliance or Health Certificate (WRAS)
- ISO 9001:2015
- ISO 14001:2015
- ISO 45001:2018
- ISO 27001:2013

Applications:

For the consumption measuring of cold potable water up to 50°C. Working pressure 16 bar (PN16), min. static pressure test 25 bar for 15 mins., 32 bar for 1 mins. Its reliability, resistance to bad water quality and noiseless operation will satisfy both end users and network managers. Meter also keeps its metrological accuracy for many years of operation, even in very difficult working conditions.

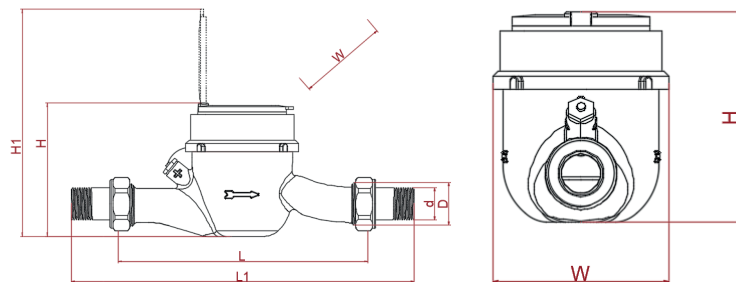

Dimension / Weight	Nominal Daimeter	Dn	mm	20
		Size	Inch	¾"
Overall Length Without Connectors	L	mm	190	
Overall Length With Connectors	L1	mm	260	
Thread Meter GxB	D	Inch	1"	
Thread Connector	d	Inch	¾"	
Total Height	H	mm	95,8	
Total Height (With Lid)	H1	mm	160,5	
Width Approx	W	mm	84,5	
Weight Approx	*	kg	0,94	
Package Without Connectors	*	kg	1,00	
Package With Connectors	*	kg	1,13	
Box Dimension (1 unite)	*	cm	19x10x9	
Package Dimension (10 unite)	*	cm	49x23x20	
Quantity Per Package	*	unite	10	

Threading : EN ISO 228-1 : 2003

Marking:

The manufacturer's trade mark, Nominal flow rate (Q3), Metrological ratio (R), Nominal size of the meter, Maximum working pressure (MAP), Pressure head loss class (ΔP), Type of the meter (Model), EC-type examination certificate number, Year of manufacturing, Mounting position, Maximum water temperature (T), CE marking, Metrology marking, Notified body number from D and F module, Volume unite of the index (m³) according to the MID 2014/32/EU directive on measuring instruments are printed on the dial.

Optional customized meter marking purchaser's logo or tender number, or QR code, serial number.

Markings which are clearly visible, readable and of permanent and non-deleteable nature may vary depending on particular markets or metrological specifications.

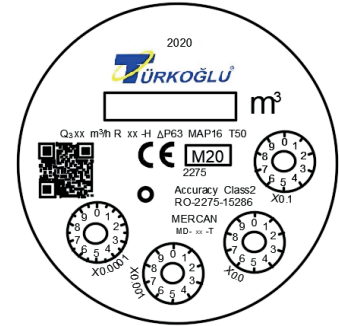

Installation and Operating Instruction:

Meter must be installed in a low point of the pipeline with the arrow cast on the body showing direction of the water flow. All pipework must be flushed out to remove all impurities before fitting the water meter. An upstream stop valve or ball valve is recommended to allow installation and removal of the water meter. When connecting the meter with the meter network, the upstream stop valve or ball valve must be opened slowly so that the meter fills the meter as smoothly as possible. No special maintenance is required.

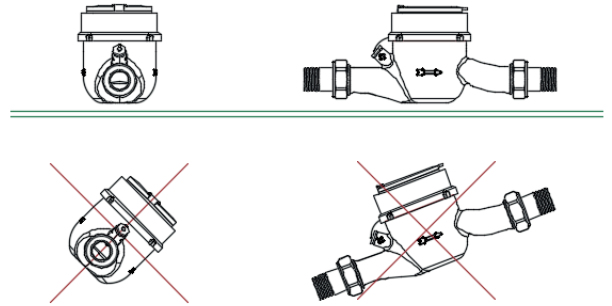

Pulse Emitter Device:

Water meter could be equipped with pulse emitter device which is a removable bonnet for quick and easy maintenance without damaging or removing the metrological seals of the meter. The meter can be linked to tele-reading systems, to PLC, to M-Bus networks using singal converter, to pulse counter and all those applications that require remote reading of the water consumption data.

Water meters could be equipped with a pulse emitter with protection class (IP68) 1,20 meter length of pre-mounted wire cables, Mercan (P) retrofittable with reed pulser: 1/10/100/1000 (Standard: 10 l/pulse, optional: 1 l/pulse) or pre-equipped for the future installation of the pulse emitter. Note: The register protective cover of water meter with pulse emitter device will be high-quality UV-resistant and made of polycarbonate (PC) transparent material instead of mineral glass.

Typical Accuracy Curve:

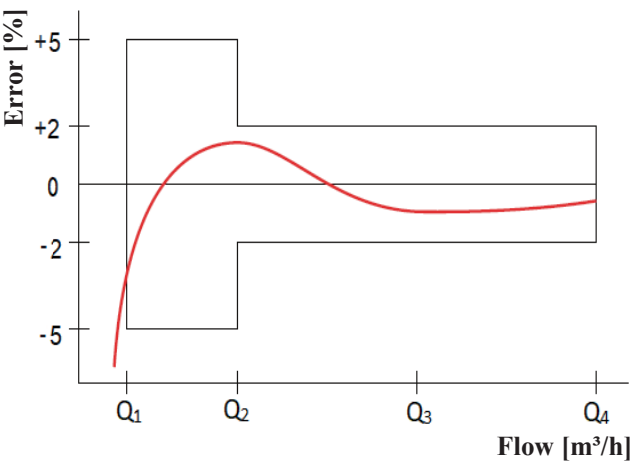

Q_1 = Minimum Flowrate Q_3 = Permanent Flowrate
 Q_2 = Transitional Flowrate Q_4 = Overload Flowrate

Typical Head Loss Curve:

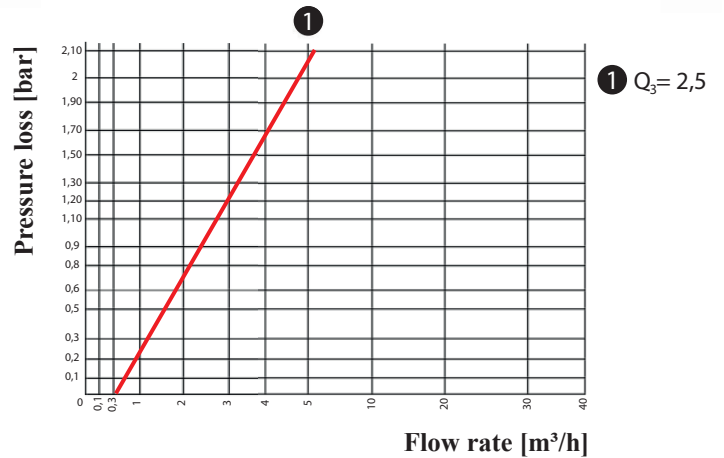

Tampering Protection and Sealing (Optional):

• Anti-Tampering butterfly seal for water meter

Pented butterfly seal consists mainly of three parts: transparent body, colored butterfly inner part and stainless steel sealing wire. Transparent body is made of polycarbonate (PC) material, colorful butterfly inner part is made of polyoximethylene (POM) which can not be removed without breaking from mounted inside. The inner part mounted inside the cylindrical body shall be non-reversible and unidirectional. Sealing wire made of AISI304 stainless steel are produced by twisting 7 pieces of Ø 0.23mm wire on top of each other. The butterfly seal can be used once against tampering in water meters. Optional: Laser printed serial number and company logo could be added on the body based on quantity.

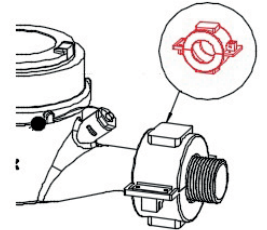
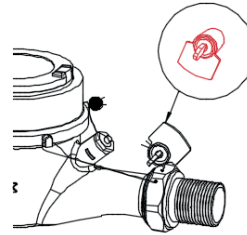

• Anti-Tampering plastic seal for water meter connectors

Plastic seal consists of two equal parts. They are made of polycarbonate (PC) material which has non-flammable, chemicals, salts, weather and ultra-violet resistant. Thickness is min.2,00 mm and not easily deform and it can not opened without breaking. There are holes on the locking mechanism suitable for the passage of the sealing wire after locking.

The materials to be used of both seals are recyclable, and the contents are not contain harmful substances to human health and environment.

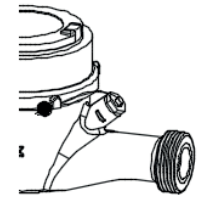
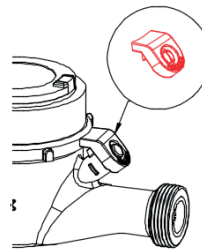

(1) Plastic Apparatus Seal

(2) Stainless Steel Seal

• Meter Seals

The meter is sealed by the plastic sealing apparatus (1) or sealing materials which are stainless steel wire (2) 1.00 mm thickness - optional (covered with plastic) and aluminium seal.

	Nominal Daimeter (DN)	DN	mm	20		
		Size	Inch	3/4"		
Performance Data	Metrological Data	Maximum Flow Rate (m ³ /h)	Q4	≤3.13		
		Nominal Flow Rate (m ³ /h)	Q3	≤2.50		
		Transitional Flow Rate (l/h) Tolerance ±2%	Q2	≤0.040		
		Minimum Flow Rate (l/h) Tolerance ±5%	Q1	≥0.025		
		Measuring Range - Horizontal (R-Class)	Q3 / Q1	100 H (Class B)		
		Measuring Transitional Flow Rate	Q2 / Q1	1.6		
		Measuring Maximum Flow Rate	Q4 / Q3	1.25		
		Accuracy Class		2		
		Performance Data	Technical Data	Maximum Permissible Error Fort The Lower Flow Rate Zone	(MPE1)	±5%
				Maximum Permissible Error Fort The Upper Flow Rate Zone	(MPEu)	±2 % for water having a temperature ≤30 °C ±3 % for water having a temperature >30 °C
Temperature Class	T °C			T30 and T50		
Water Pressure Classes	MAP (Bar)			16		
Pressure - Loss Classes	Δ P (Bar)			0,63		
Max. Indicating Range	[m ³]			99 999		
Resolution Of The Indicating Device	[litre]			0,05		
Installation Positions				H		
Flow Profile Sensitivity Classes				U0 D0		
Impulse Value	litre/pulse			1 , 10 , 100 , 1000		
ModuleType (Optional)		Pulse, MBus (Wired,Wireless), RF, AMR				

Third Party Inspection Company (Optional)

Third Party Inspection company (Bureau Veritas, SGS, Intertek) can be attended and witness to the needed tests in order to ensure 100% complete matching between the product and what is required in tender or contract documents in terms of standards, specifications and conditions.

Third Party Inspection report could be provided to the purchaser with results of all tests performed including visual, quality, quantity, packing, marking, loading control and witnessing to hydrostatic tests, error of indication tests during the inspection before each shipment.

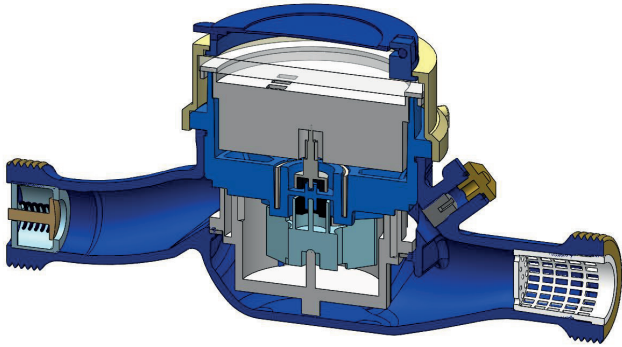

	MATERIAL
1	BODY (BRASS)
2	LID
3	GLASS
4	REGISTER CAP (BRASS)
5	GASKET
6	REGISTER
7	CENTRAL GEAR
8	ANTIMAGNETIC METAL RING
9	CLAMPING METARIAL
10	TURBINE / VANE WHEEL
11	MEASURING CHAMBER
12	ADJUSTING PLUG
13	ADJUSTING SCREW
14	STRAINER
15	NON - RETURN VALVE

Legibility & Reliability:

• Register / Counter

The register is direct straight reading type and consists of five (5) digits numeric rolls for m³ and four (4) pointers circular for litres to ensure perfect readability. The lowest resolution is 0,05 litres. The dial has a central disc (black or red) whose rotation indicates the passage of water. This indicator can be used to reveal a downstream leak. The register is also suitable for test on an electronic test bench.

The register is extra-dry dial and hermetically sealed (IP68) with magnetic transmission. It registers in cubic meter units and protected by a resistant lid. The pivot of impeller chamber, turbine which is supported by a sapphire and rested on a stainless steel shaft are made to guarantee against any corrosion or damage. Suitable for pre-equipped or equipped for the communication.

• Meter Body / Housing

The body/housing of the water meter, threaded type, made of brass alloy (press or cast) containing not less than 58% copper- corrosion protected by epoxy powder coating both inside and outside. A visible arrow on both sides of the body shows the direction of water flow.

• Register Ring (Cap)

Register Ring (Cap) made of press brass alloy containing not less than 58% copper. The material can be accessible or removable in order to maintain the internal parts of the meter. Manufacturer's meter serial number are engraved on the register ring (Cap) covering the meter.

• Register Protective Cover (Glass) and Register Cover (Lid)

The register protective cover is made of sturdy mineral glass to avoid condensation or enable the reading anyway, has a thickness of min. 5 mm which prevents any mechanical tempering and scratch resistance. The magnetic transmission interface is tamper-proof (protection from external magnetic influences). The protection of register mineral glass (lid) is 360° rotating and made of hard polymer.

• Strainer and Non-Return Valve

Larger particles (dust, stone, etc.) in water can be filtered by a cleanable tubular, durable internal removable strainer at the flow inlet to the meter, without dismantling the meter and/or braking the seal. Durable internal non-return valve is integrated at meter body/housing at outlet-side.

• Connector For Meter

Set of connectors for water meter comes with a set of klinger-seal or EPDM rubber gaskets and one set of brass couplings (tailpieces, nut) threaded to correct male size that are resistant to corrosion. The thread conform to ISO 228-1 standard.

Optional: (2) Coupling nut on tailpiece can be drilled for sealing wires.

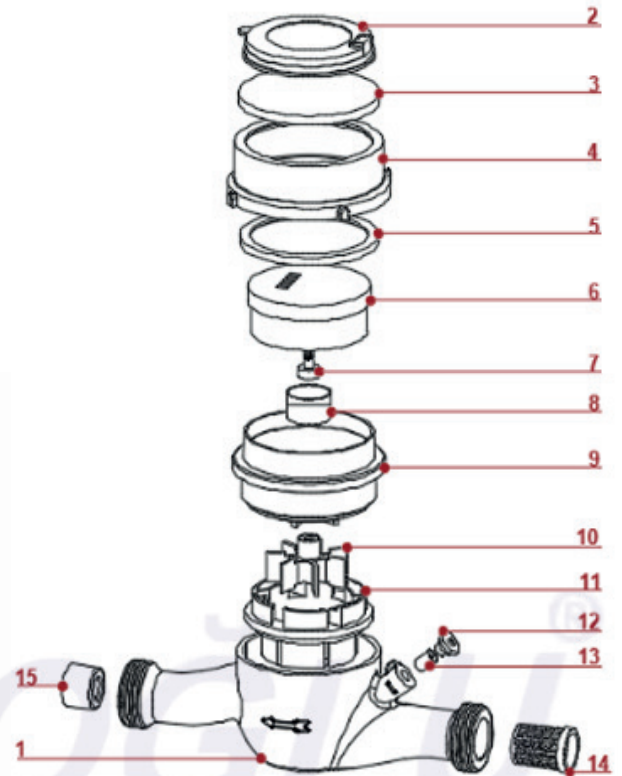

(1) Connector without hole for sealing (2) Connector with hole for sealing